

Stock No.543

Adjustable bench level

- The bubble tubes are exposed for ease of reading.

■ Dimensional drawing Unit : mm

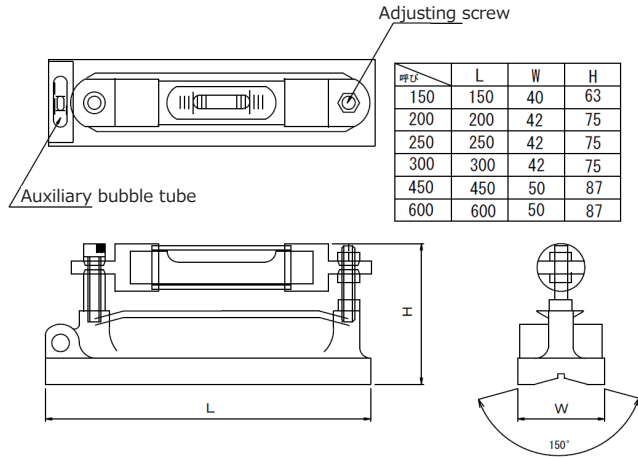
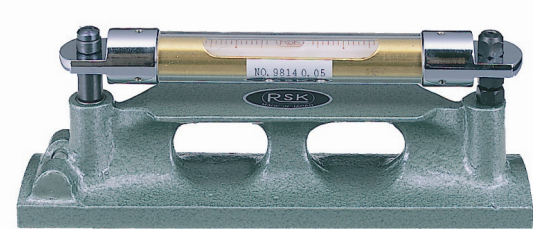

Features

- The sensitivity of these levels can be selected from among 0.05 mm/m and 0.1 mm/m.

Configuration of stock number

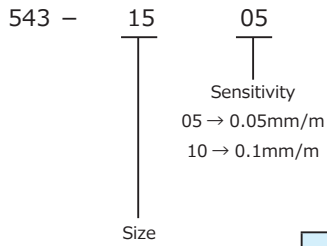

Material : Cast iron
Package : Wooden box ,Carton
Accessories : Certificate of conformity

Product No	Stock No	Size (mm)	Sensitivity (mm/m)	Weight (kg)
11-05-150	543-1505	150	0.05	0.9
11-05-200	543-2005	200		1.3
11-05-250	543-2505	250		1.7
11-05-300	543-3005	300		2.2
11-05-450	543-4505	450		4.5
11-05-600	543-6005	600		6.5
11-10-150	543-1501	150	0.1	0.9
11-10-200	543-2001	200		1.3
11-10-250	543-2501	250		1.7
11-10-300	543-3001	300		2.2
11-10-450	543-4501	450		4.5
11-10-600	543-6001	600		6.5