

Stock No.583

Magnetic square precision level

- These levels can measure an inclination of columnar items.
- These levels have accuracy equivalent to JIS Grade A.

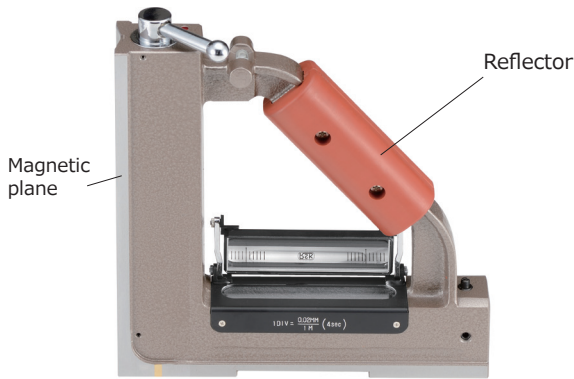

■ Dimensional drawing Unit : mm

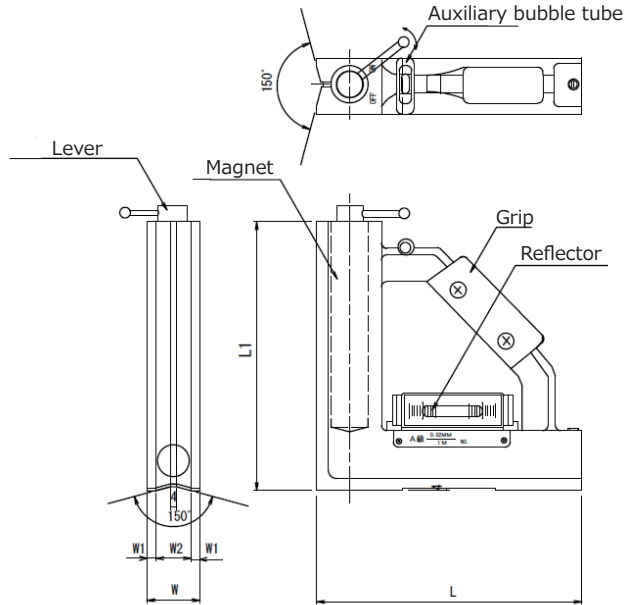

Features

- By sticking magnetic planes to columnar items, the angularity can be measured with high accuracy.
- Since the magnetic plane sticks to an item to be measured, an indicated value can be read even when removing your hand. This allows for safer measurement in high places.
- A measured value can be read easily with the reflector.

Size	L	L 1	W	W1	W2
150	160	153	35	6.5	22
200	200	200	40	6.5	27
250	250	250	41	6.5	28



Material : Cast iron(Bottom) ,S50C (Magnetic plane)
 Package : Wooden box ,Carton
 Accessories : Hexagonal wrench, Certificate of inspection, and Instruction manual

Configuration of stock number

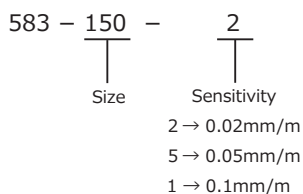

- * For the smallest model (150 mm), a reflector is not provided.
- * This level do not have an air chamber.

Product No	Stock No	Size (mm)	Sensitivity (mm/m)	Squareness (±μm)	Weight (kg)
09-02-150	583-1502	150	0.02	2.2	2.2
09-02-200	583-2002	200		3.0	3.2
09-02-250	583-2502	250		3.7	4.9
09-05-150	583-1505	150	0.05	3.7	2.2
09-05-200	583-2005	200		5.0	3.2
09-05-250	583-2505	250		6.2	4.9
09-10-150	583-1501	150	0.1	3.7	2.2
09-10-200	583-2001	200		5.0	3.2
09-10-250	583-2501	250		6.2	4.9