

普及型 寸法表

●寸法は、STEEL寸法です。SUS、C3604寸法は、多少変わります。

SH(ホースニップル型)

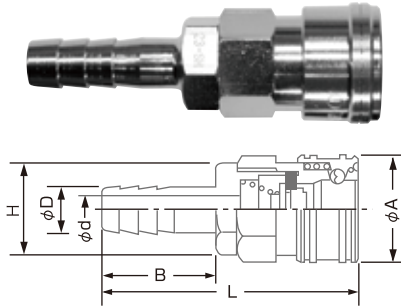

型式	ホースサイズ	寸法(mm)					
		L	φA	B	φd	φD	H
22-SH	1/4"ホース	72.5	26.5	30	5	9	19
23-SH	3/8"ホース	76.5	26.5	34	7.5	11.3	19
24-SH	1/2"ホース	78.5	26.5	36	9	15	19
44-SH	1/2"ホース	84	36.5	36	9	15	29
46-SH	3/4"ホース	93	36.5	45	13	21	29
48-SH	1"ホース	103	36.5	55	20	27	29

PH(ホースニップル型)

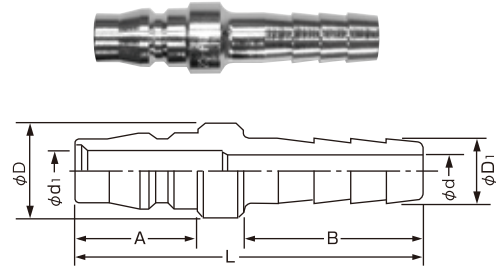

型式	ホースサイズ	寸法(mm)						
		L	φD	A	B	φD1	φd	φd1
22-PH	1/4"ホース	58	16	20	30	9	5	7.5
23-PH	3/8"ホース	62	16	20	34	11.3	7.5	7.5
24-PH	1/2"ホース	64	20	20	36	15	7.5	7.5
44-PH	1/2"ホース	67	22	23	36	15	9	13
46-PH	3/4"ホース	76	30	23	45	21	13	13
48-PH	1"ホース	86	34	23	55	27	20	13

SM(オネジ型)

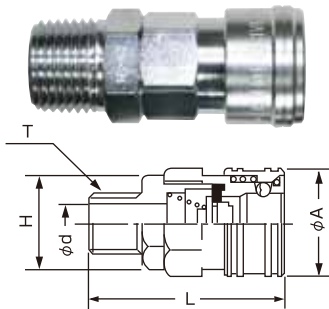

型式	適用サイズ (PT)	寸法(mm)					
		L	φA	φd	T(PT)	H	
22-SM	R1/4"	55.5	26.5	7	R1/4"	19	
23-SM	R3/8"	56.5	26.5	8	R3/8"	19	
24-SM	R1/2"	59.5	26.5	9	R1/2"	22	
44-SM	R1/2"	64	36.5	13	R1/2"	29	
46-SM	R3/4"	66	36.5	16	R3/4"	32	
48-SM	R 1"	70	36.5	22	R 1"	36	

PM(オネジ型)

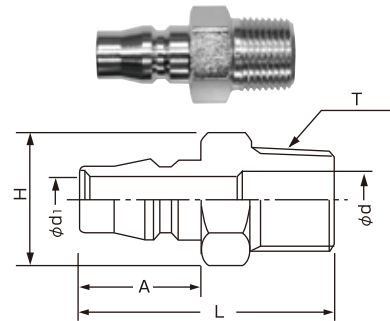

型式	適用サイズ (PT)	寸法(mm)						
		L	A	T(PT)	φd	φd1	H	
22-PM	R1/4"	42	20	R1/4"	7.5	7.5	14	
23-PM	R3/8"	43	20	R3/8"	7.5	7.5	19	
24-PM	R1/2"	46	20	R1/2"	12	7.5	22	
44-PM	R1/2"	47	23	R1/2"	13	13	22	
46-PM	R3/4"	49	23	R3/4"	19	13	32	
48-PM	R 1"	53	23	R 1"	22	13	35	

SF(メネジ型)

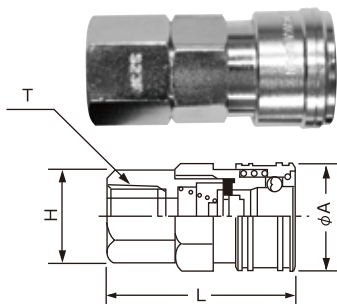

型式	適用サイズ (PT)	寸法(mm)				
		L	φA	T(PT)	H	
22-SF	Rc1/4"	50.5	26.5	Rc 1/4"	19	
23-SF	Rc3/8"	50.5	26.5	Rc 3/8"	21	
24-SF	Rc1/2"	52.5	26.5	Rc 1/2"	29	
44-SF	Rc 1/2"	58	36.5	Rc 1/2"	29	
46-SF	Rc3/4"	61	36.5	Rc 3/4"	35	
48-SF	Rc 1"	68	36.5	Rc 1"	41	

PF(メネジ型)

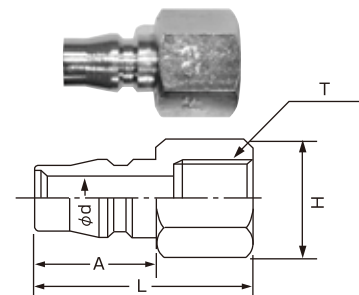

型式	適用サイズ (PT)	寸法(mm)				
		L	A	T(PT)	φd	H
22-PF	Rc1/4"	37	20	Rc1/4"	7.5	17
23-PF	Rc3/8"	38	20	Rc3/8"	7.5	21
24-PF	Rc1/2"	39	20	Rc1/2"	7.5	29
44-PF	Rc1/2"	41	23	Rc1/2"	13	29
46-PF	Rc3/4"	43	23	Rc3/4"	13	35
48-PF	Rc 1"	51	23	Rc 1"	13	41