

## Stock No.600

### Cross-test precision level(T-type)

- The horizontality in the X-axis and Y-axis directions can be measured simultaneously only with these levels.



#### Features

- The horizontality of the X-axis and Y-axis on the same plane can be measured simultaneously.
- The vertical and horizontal bubble tubes have an adjusting screw, respectively, to center the bubbles.

■ Dimensional drawing Unit : mm

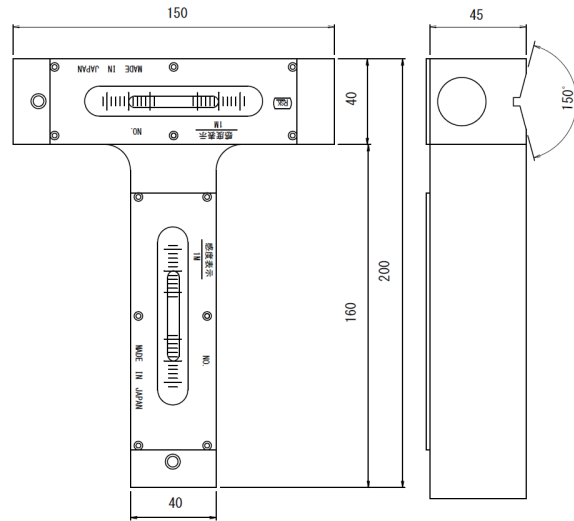

#### Configuration of stock number

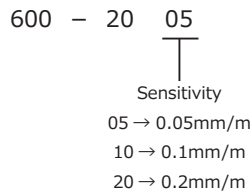

Material : Cast iron  
 Package : Wooden box ,Carton  
 Accessories : Certificate of conformity

Product No	Stock No	Sensitivity (mm/m)	Weight (kg )
12-05	600-2005	0.05	2.7
12-10	600-2001	0.1	
12-20	600-2002	0.2	

## Stock No.252

### Portable level

- Small level with emphasis on portability.



#### Features

- Despite their small size, these levels have an adjusting screw to center the bubbles.
- These levels have accuracy equivalent to the flat-type levels for standard type.

■ Dimensional drawing Unit : mm

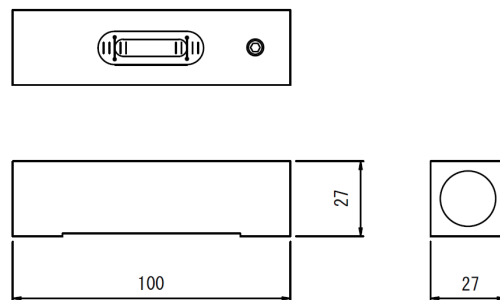

Material : Cast iron  
 Package : Carton  
 Accessories : Certificate of conformity

#### Configuration of stock number

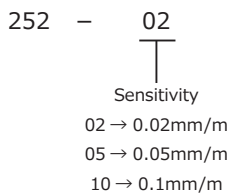

Product No	Stock No	Sensitivity (mm/m)	Weight (kg )
15-02	252-02	0.02	0.34
15-05	252-05	0.05	
15-10	252-10	0.1	